



# Tecwire Strut-Lock System TWSTRUT



## Description

The M8 & M10 tecwire strut-lock system is used to support HVAC and M&E services from the Y-RANGE of Zip-Clip wire supports. The devices are typically installed into profile channel which can then be hung from a wire.

## Features

- 18th Edition Amendment 2 : 2022 compliant.
- Versatile – Use with channel nuts or nuts and washers (metric only).
- Quick to install and adjust.
- Safe Working Load (SWL) -  
M8 of 45kg each per suspension.  
M10 of 90 kg each per suspension.
- Secure lock-off.
- Manufactured from mild steel.
- Bright zinc plate finish.

## Applications

- Single-tier trapeze brackets.
- Multi-tier trapeze brackets.
- Attach to existing bracketry.
- Compatible with 41×41 and 41×21 profile channels plus other channel types when compatible channel nuts are used (metric only).

## Fixing Options

The M8 & M10 Strut-Lock system is available with the following fixing terminations:

**Loop end:** To form a choke knot for wrap-around anchor points such as purlins or I-beams. Ensure anchor points are suitable.

### M6 concrete hammer fixing:

BS8539 approved with ETA, offering shallow embedment into cracked and non-cracked concrete. Ensure base material is suitable.

sales@lindab.co.uk

## Dimensions

### M8

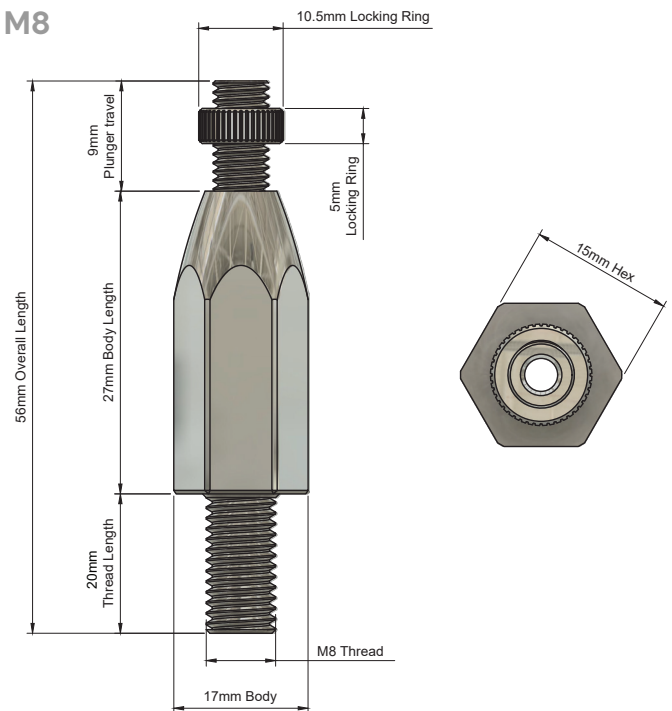

### M10

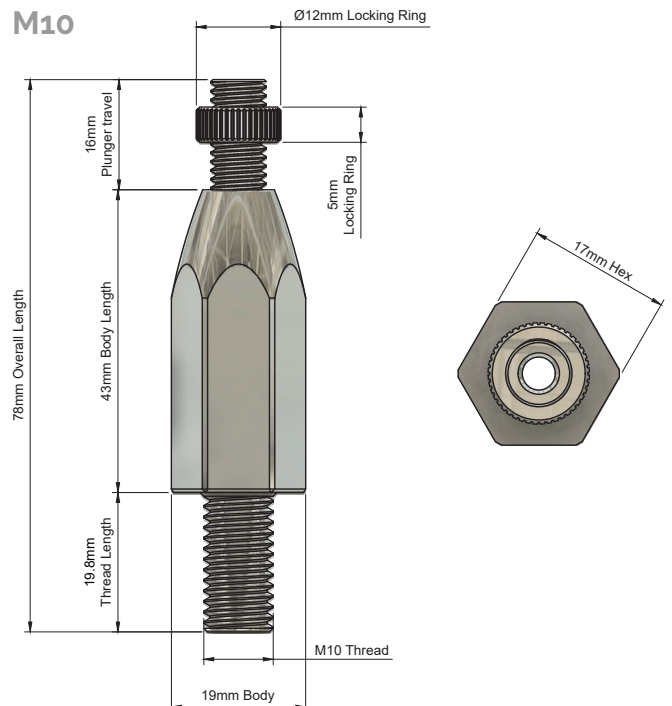



# Tecwire Strut-Lock System TWSTRUT

## Installation

Locating a Strut-Lock Device Into Channel – Building a Single-tier Trapeze Bracket:

1. Couple with square washer and channel nut.
2. Position assembly into desired channel location.
3. Tighten into position using a 15/17 mm spanner. Turn clockwise.
4. Back-off the locking collar. Do not undo fully. Depress plunger.
5. Insert wire rope through the plunger at the top of the device.
6. Adjust the position by depressing the plunger and moving along on the wire.
7. Once the trapeze bracket is in position, release the plunger and wind the locking collar up to the shoulder.
8. Lock the trapeze position by turning the locking collar clockwise.

Repeat steps 1 - 8 to build a multi-tier bracket

**Torque setting:** It is recommended that the Strut-Lock device is not overtightened during installation. If it is possible to apply a torque value during installation, this should be no more than 15 Nm.

### To undo:

1. Undo locking collar.
2. Depress plunger.
3. Reposition device to required height.
4. Re-lock collar.

### Please note:

Always ensure the load is supported before actuating the plunger to perform adjustment.

## Recommendations

The Tecwire Strut-Lock system is designed to support **STATIC** loads only.

Dynamic and shock loads must be avoided and can greatly increase the overall weight of the product being suspended and therefore compromise the Safe Working Load of the suspension. Always take into account the nature of the install process. Beware of dynamic or shock loading.

- Do not exceed the Safe Working Load (SWL) of the product.
- Do not use for angled wire supports.
- Do not use locking devices with a coated cable.
- Do not paint or apply any other coating.
- Do not lubricate.
- Do not use for lifting applications.
- Remove any frayed cable prior to inserting into the locking devices.
- Do not shock load.
- Do not use for dynamic loads/installations.
- Do not overload.

